

03

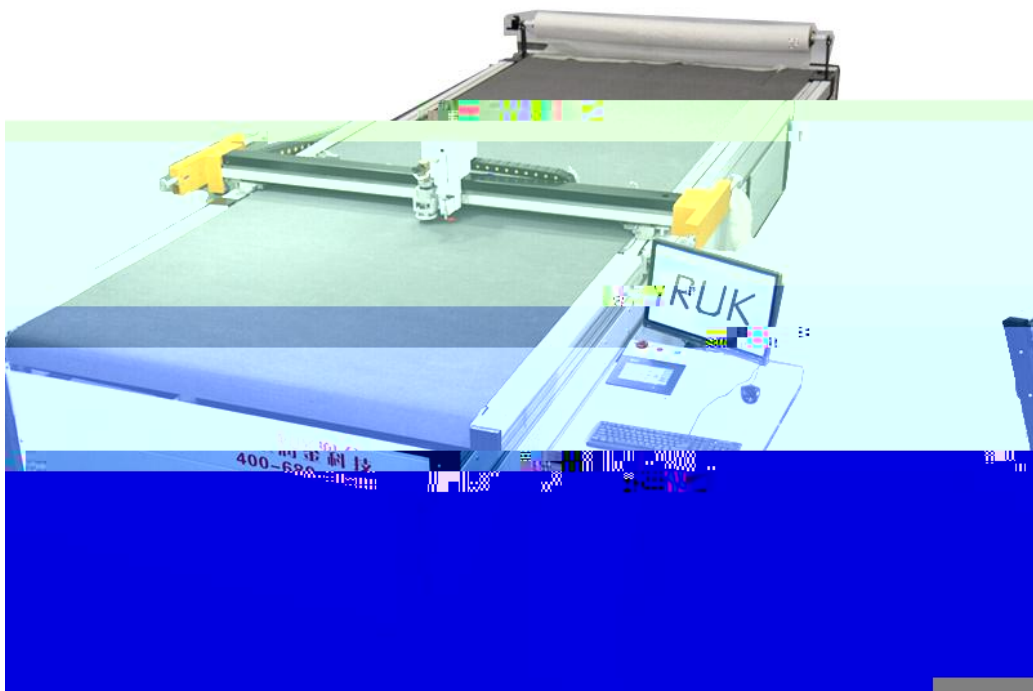



<b>RJ</b>	.....	<b>4</b>
1-1		4
1-2		4
1-3		4
1-4		5
1-5		7
1-6		7
1-7		8
	.....	
2-1		10
2-2		10
2-3		11
1		11
2		11
3		11
4		12
5		13
6		13
7		14
8		15
9		15
2-4		16
2-5		19
2-6		20
	.....	<b>20</b>
	.....	<b>21</b>
	.....	
	.....	<b>23</b>

•

•

•

•

•

•

•

•

•

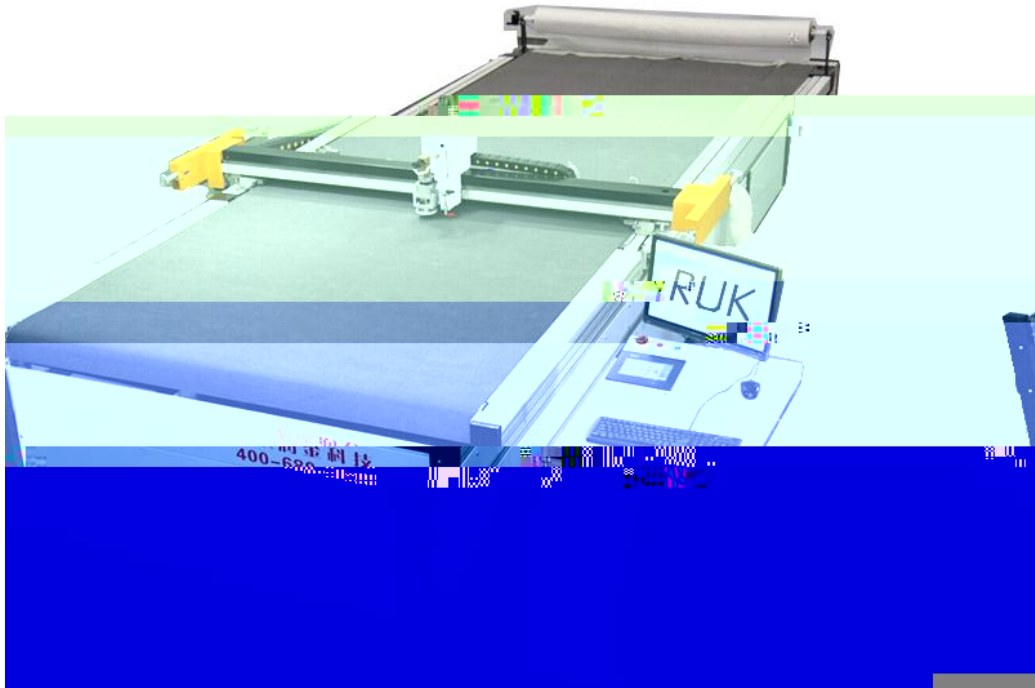

1-1

2)

1

2



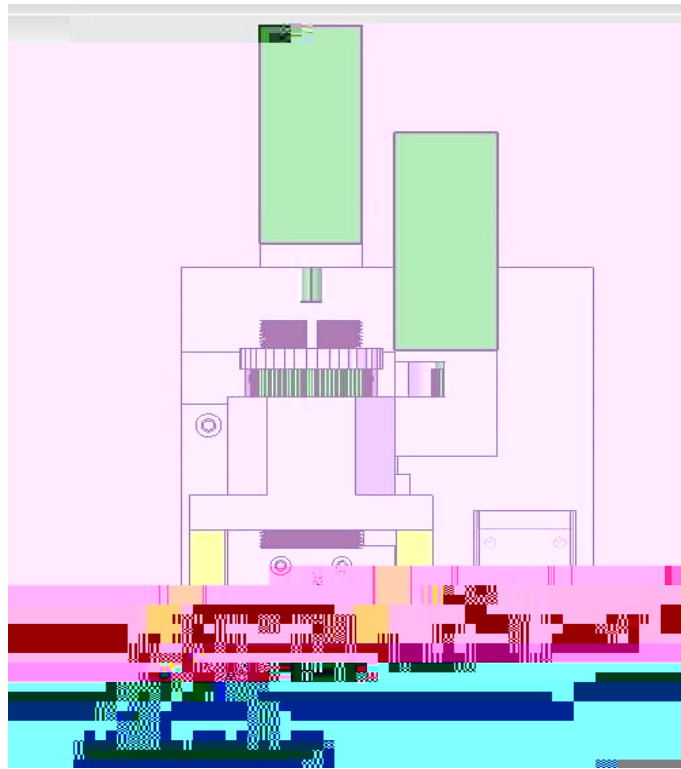

1-3

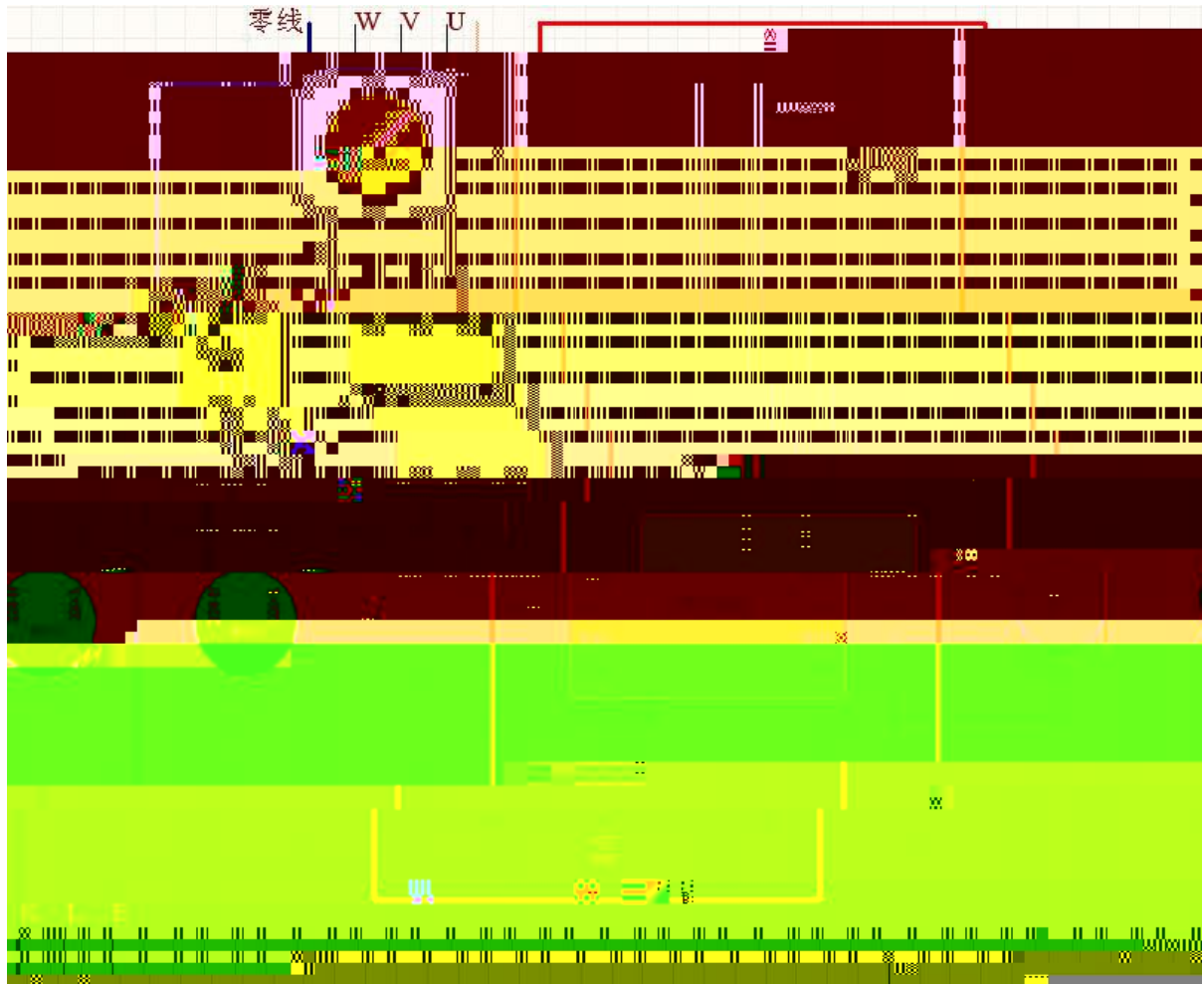

1-4

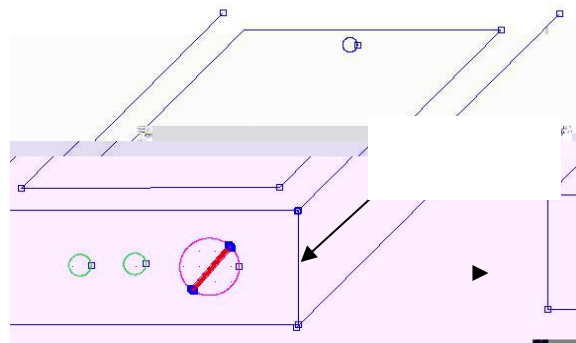



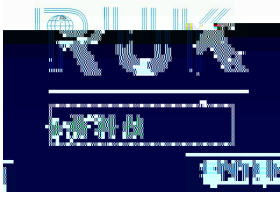

ENTER

2)

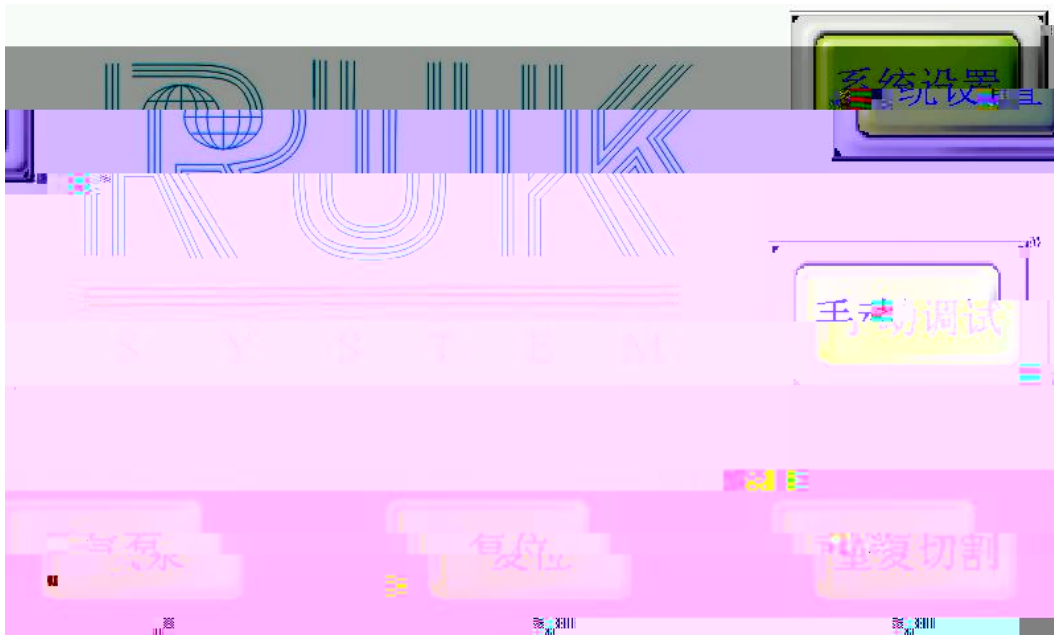

2-2

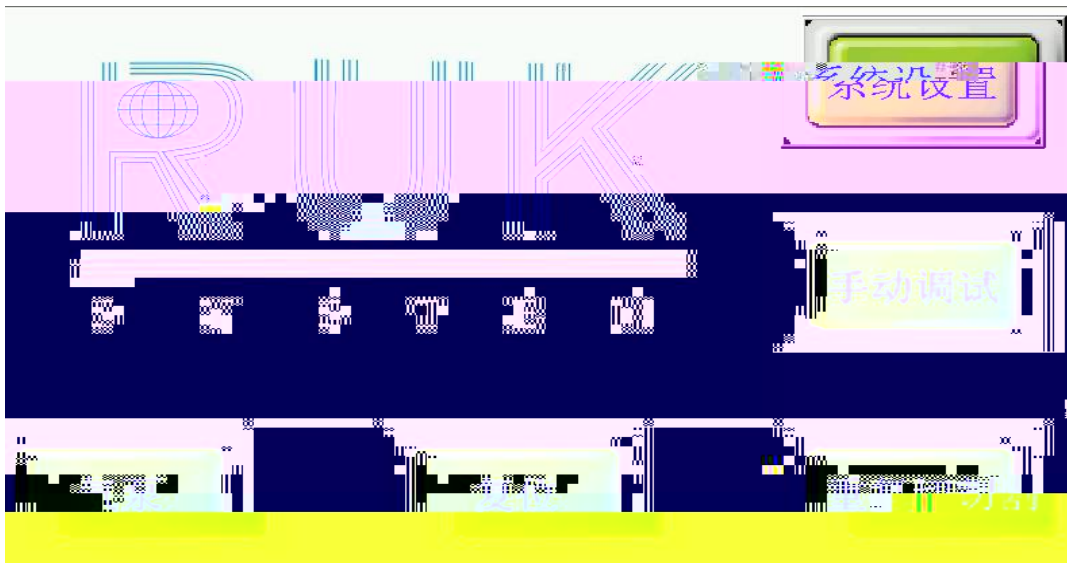

2- 3

1



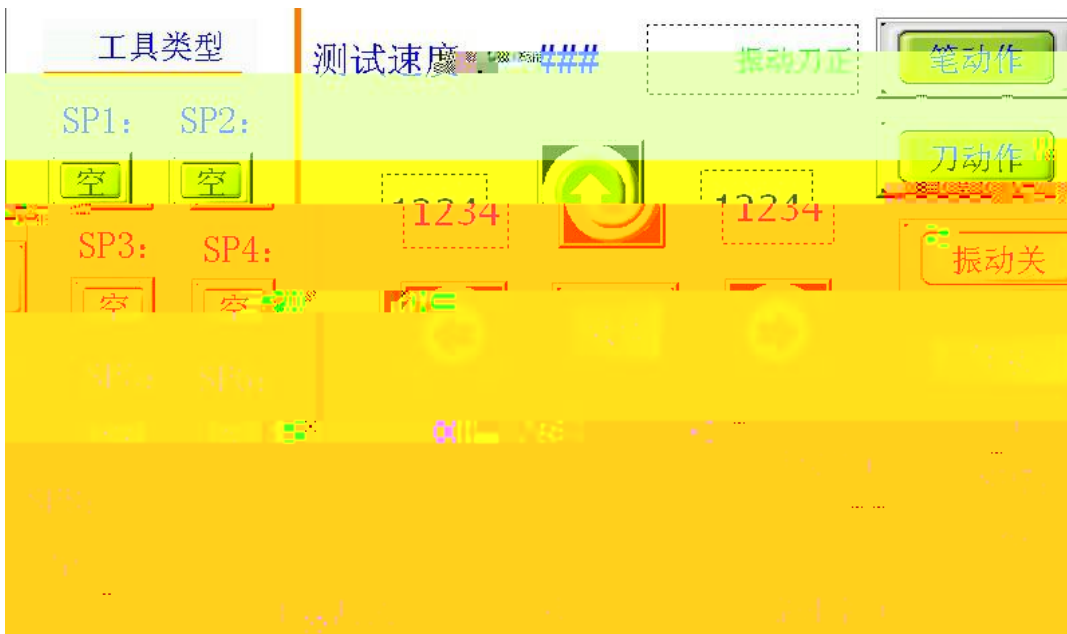

2

3



2- 4

- |   |  |  |       |
|---|--|--|-------|
| 1 |  |  | X" "  |
| 2 |  |  | X" -" |

- 3   Y" +"
- 4   Y" -"
- 5 / /
- 6 ;
- 7 ;
- 8 X Y 1/10
- 9



2- 5

- 1   " " " "
- 2    
- 3 " "
- MM .
- 4
- 5

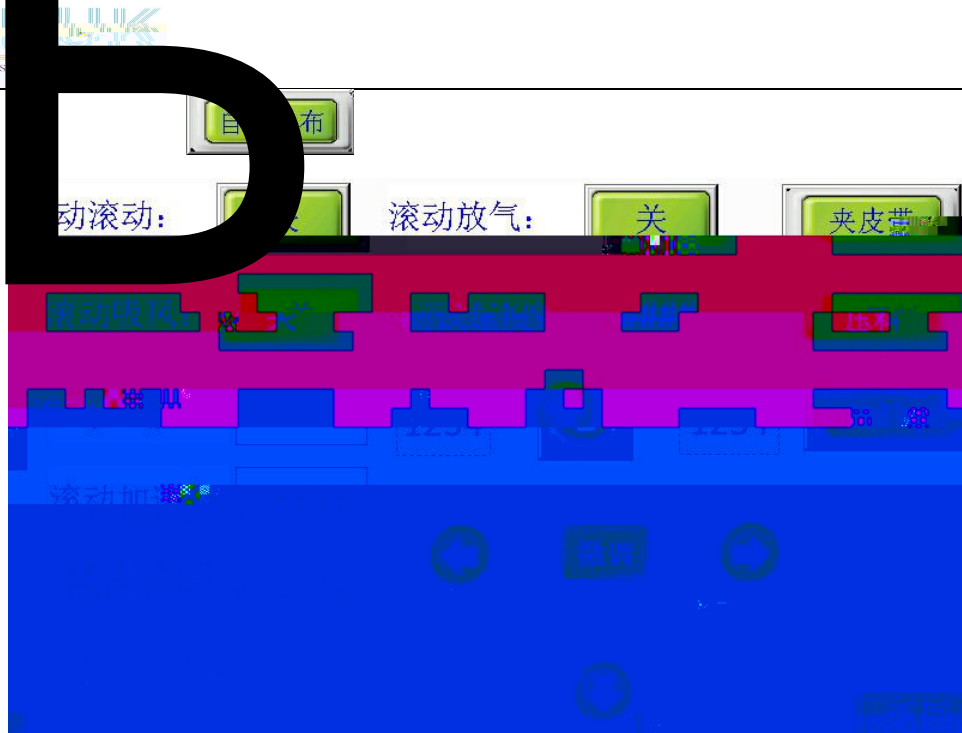

- 1
- 2
- 3
- 4
- 5
- 6

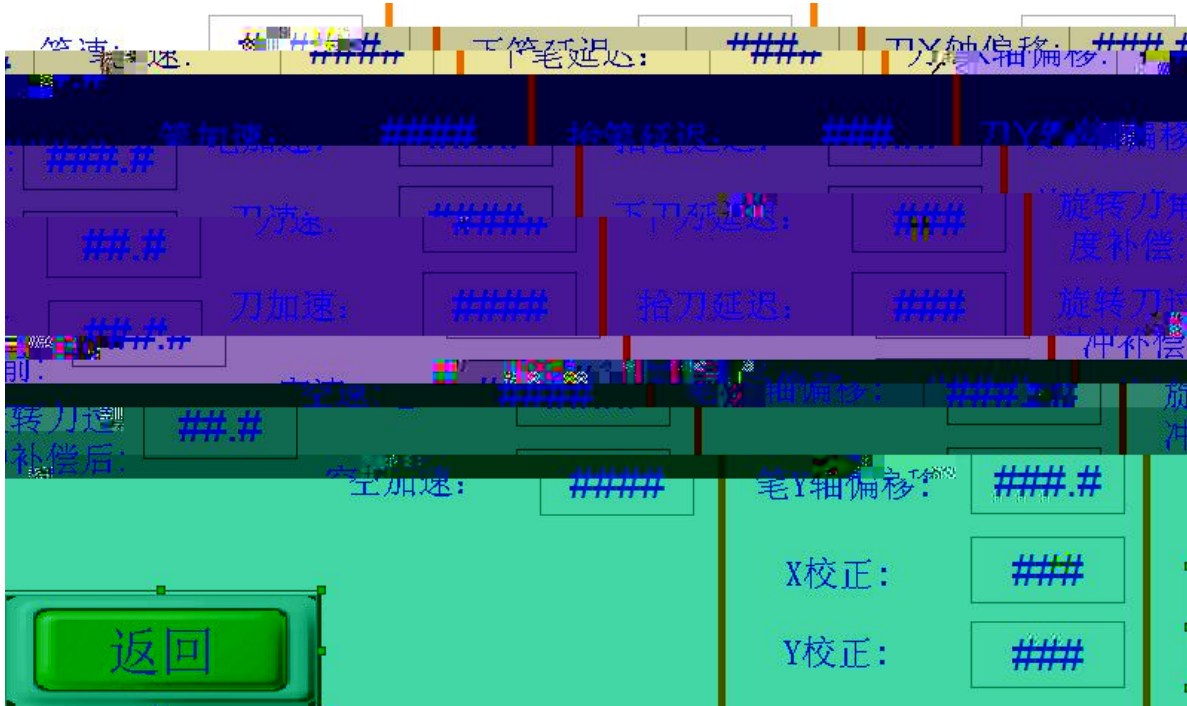

2- 7

- 1
- 2
- 3
- 4
- 5
- 6
- 7 X X
- 8 Y Y
- 9 X X U
- 10 Y Y U
- 11 X X
- 12 Y Y
- 13 N
- 14 N
- 15 N
- 16 N
- 17
- 18 MM
- 19 MM

8



2-8

- 1
- 2
- 3
- 4
- 5
- 6
- 7
- 8

9

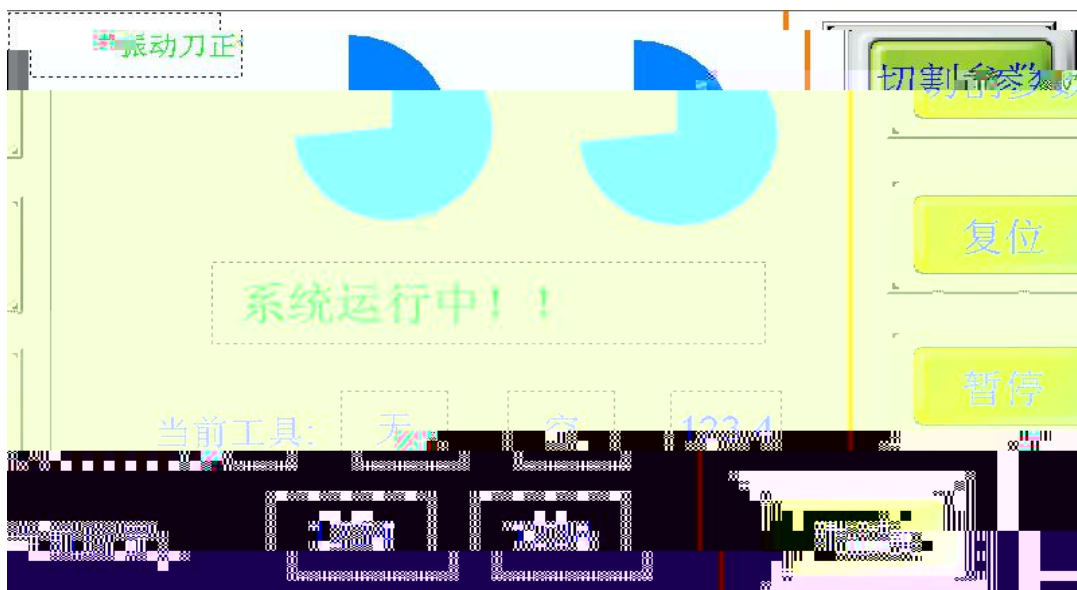

2-9

1  
2  
3  
4  
5  
6  
10

## 切割参数

笔速: ##### 中间深度: ###.#  
笔加速: "##### 全刀深度: ###.#  
刀速: +##### 半刀深度: ###.#  
刀加速: #####  
空速: #####



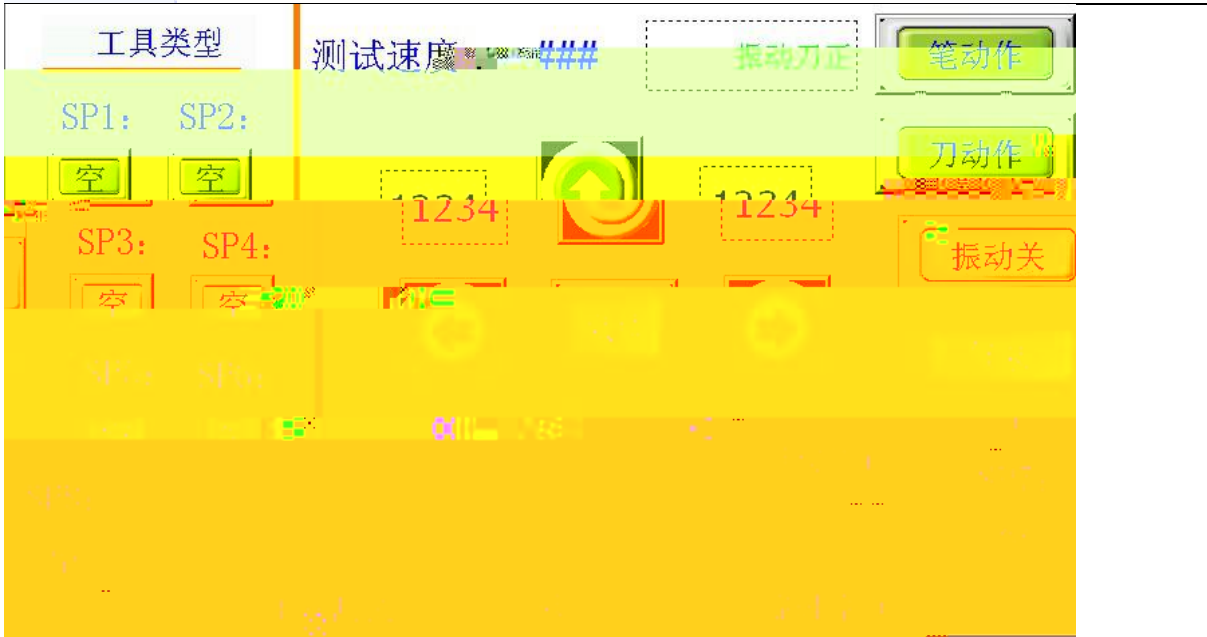

2-11

2

ENTER " " " " " 3000"

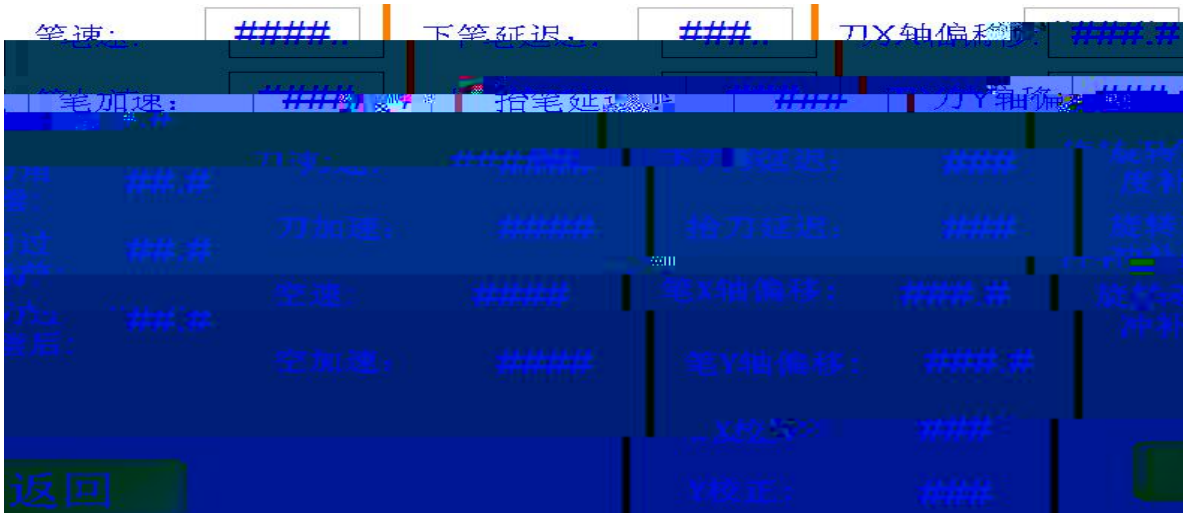

2-12

3 Ethernet

Ethernet

1 " " " "

2 " " " "

3 IP IP " 192.168.0.26" IP  
" 192.168.0.250"

4 Ethernet IP m

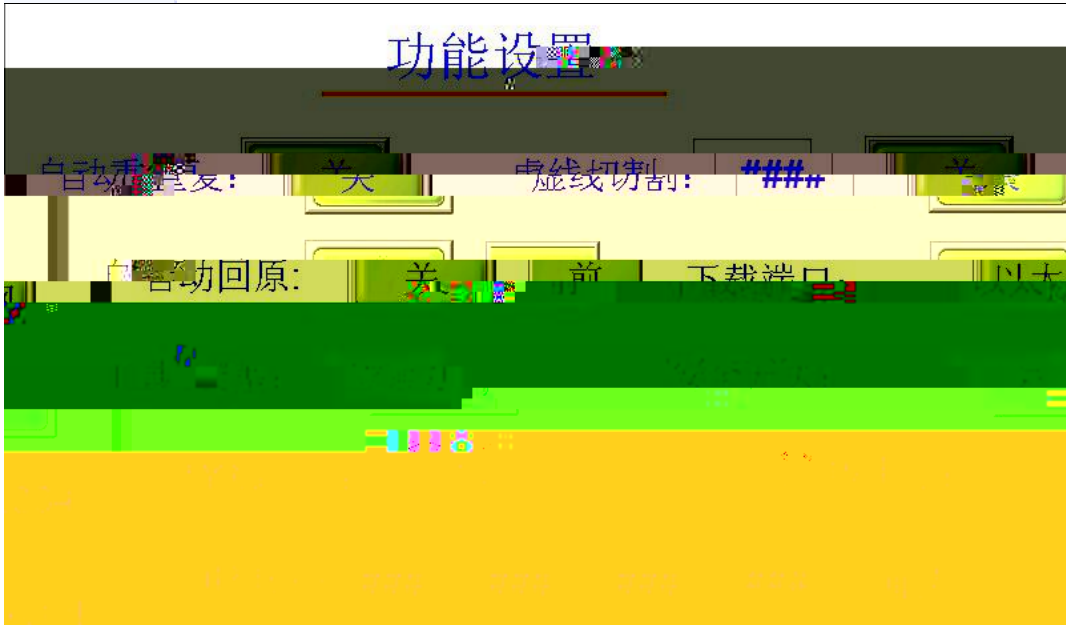

2-13

4

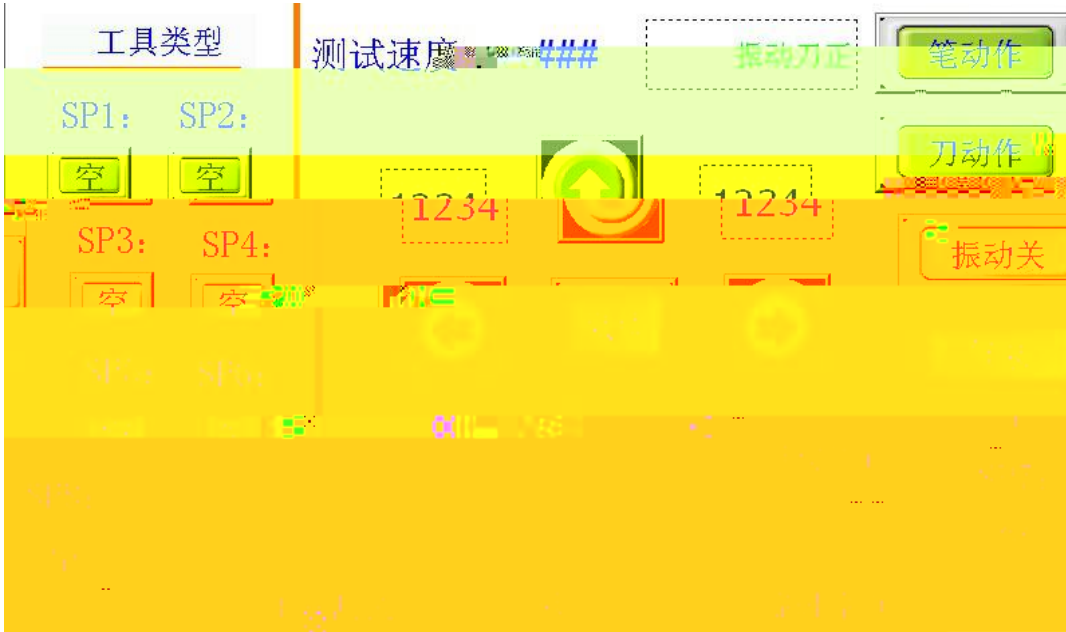

2-14

" "

" " " X / " " Y / "

" "

" "

2-5



2-15

1)

"

"

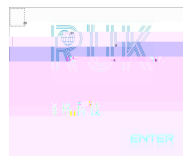

2

"

"

ENTER

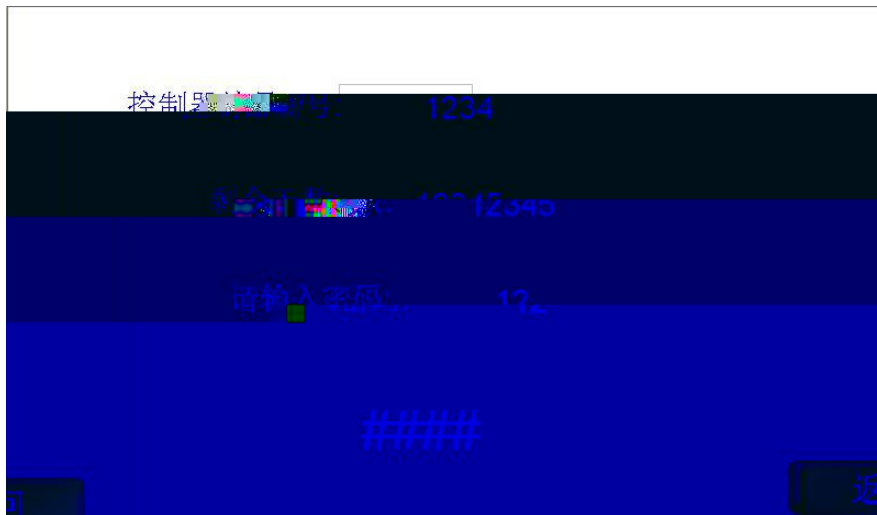

2-16

2-6

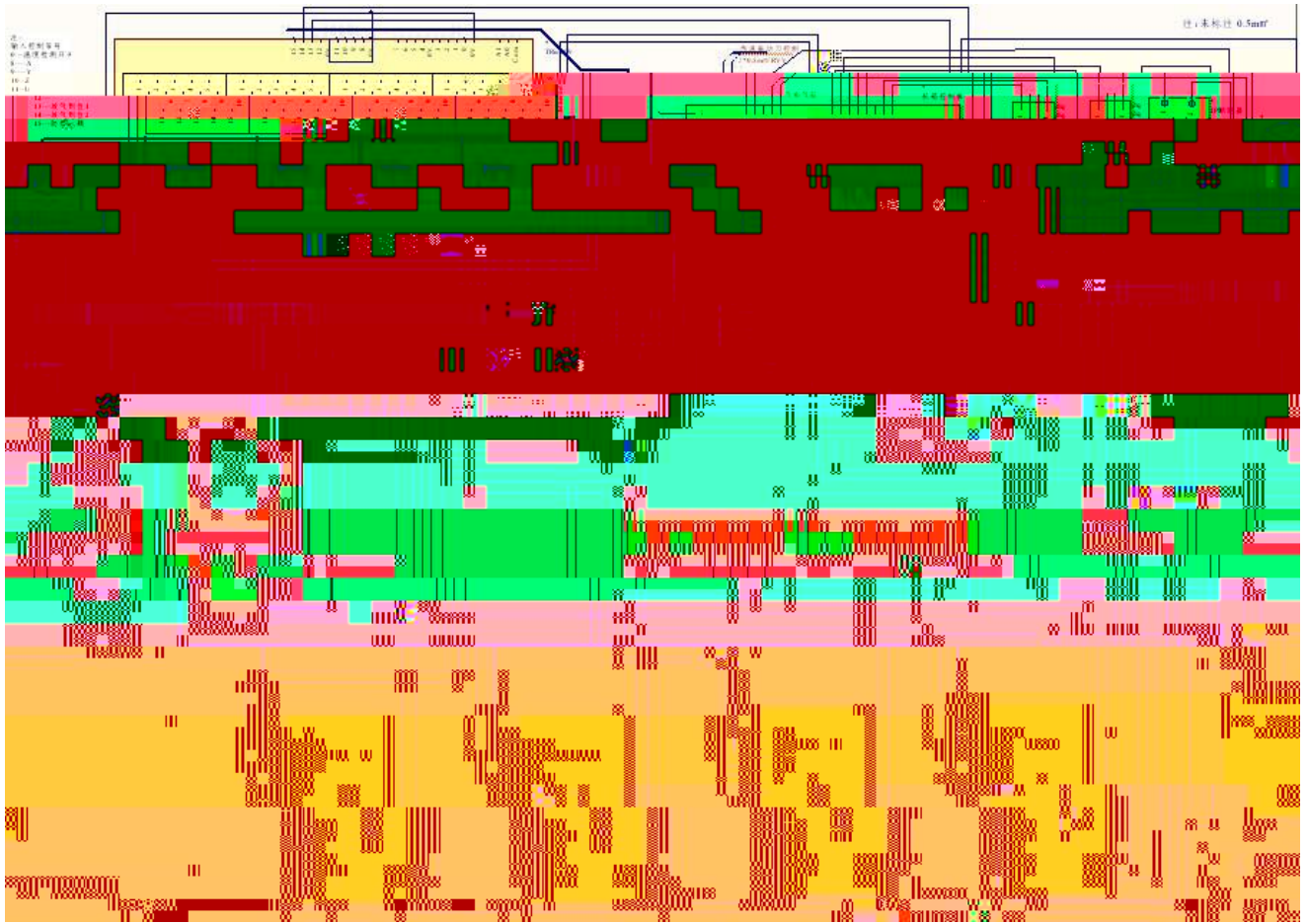

220V/ 380V, 15KW





F > A 77 \$ ' ! % ) % \* F > A 77 \$ ' ! % , F > A 77 \$ ' ! & ) % \* F > A 77 \$ ' ! & ) % ,

\* \$ \$ ! ! % \$ \$ \$ a # g





S

U  
U1  
X  
Y

U  
U1

U  
U1

V-Cut

V-Cut

V-Cut  
V-Cut

V-Cut

X  
Y

U X  
U Y

U1 X  
U1 Y  
X  
Y

U

U1

